

# TSPB Factory

## M7 Advanced Manufacturing Division

Original Equipment  
Manufacture

# Advanced Manufacturing Division Overview

Distribution : ■ 100% OEM/ODM  
No Employees : 189

- Original Equipment Manufacturer
- Original Design Manufacturer
- High vacuumed chamber manufacturing & assembly
- Ultra precision machining parts sourcing & manufacturing
- Components localized
- Commercial parts sourcing service

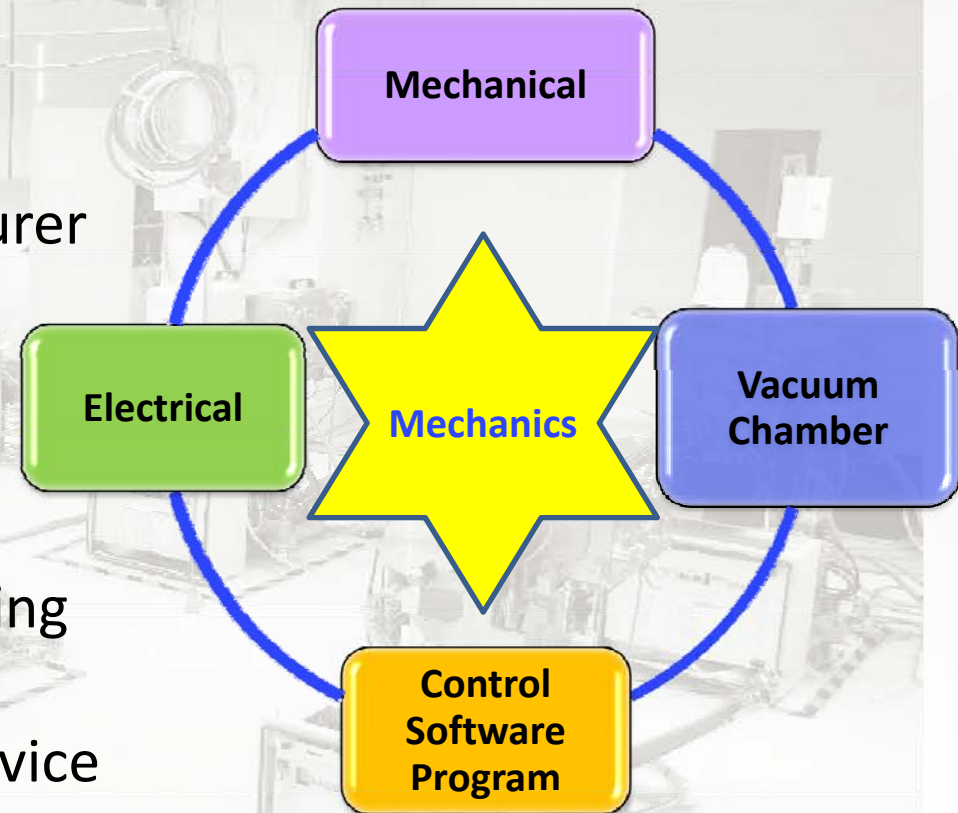

# 5 Assurance

## Assembly

Assembly

Quality

Logistic

Flexibility

Technical Support

- Workmanship
- Time-Cost Saving
- SOP



## 5 Assurance

### Quality

Assembly

Quality

Logistic

Flexibility

Technical Support

- Aiming for defects reducing
- Delivering products and services beyond our customers' expectation



# 5 Assurance

## Logistic

Assembly

Quality

Logistic

Flexibility

Technical Support

- Guaranteed JIT/On time delivery
- ERP implementation and control.
- Mature Supply Chain Management (SCM)



## 5 Assurance

### Flexibility

Assembly

Quality

Logistic

Flexibility

Technical Support

- Our human capital provides the best and most efficient allocation
- Build to print or Build to spec.



# 5 Assurance

## Technical Support

Assembly

Quality

Logistic

Flexibility

Technical Support

- Design & Development
- Co-Engineering
- Trouble Shooting

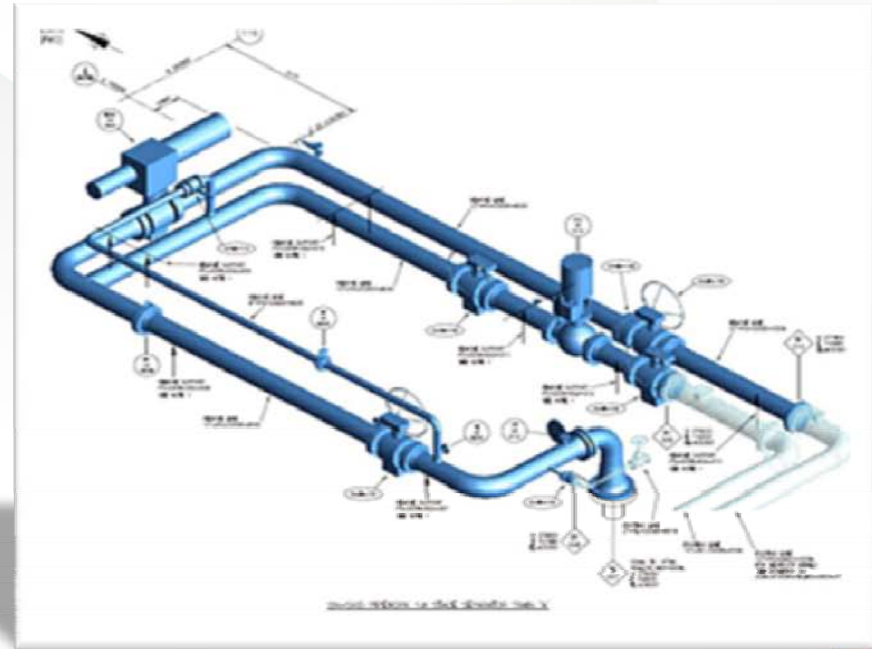

# Certificates & Awards

Certification	Type	Grantor
ISO 9001:2008	Quality System	Industry Sector Certification LTD.
ISO 14001: 2004 OHSAS 18001: 2007	Quality system	Industry Sector Certification LTD
SEMI S2	Factory Inspection	TUV Taiwan
Third Party FAI	14 prototypes of RF Matches	SQA service, Inc.
Integrated Supplier Assessment Tool	Approved Supplier	Applied Material
Best Supplier in Asia Earned 2008 Jan	Approved Supplier	AKT
Golden & Diamond Unit	Fixload 6M	Brooks Automation



POWERED BY STEPQ<sup>SM</sup>





# AEC- Authorized Economic Operator 進出口通關優質企業認證



# WORKING ON YOUR SUCCESS

